

Technical specifications

Base machine system Gallus ECS 340

| Machine specifications | | |
|-------------------------------|----------|------------|
| Mechanical machine speed max. | 60 m/min | 197 ft/min |
| Web width max. | 345 mm | 13.7" |
| Web width min. | 170 mm | 6.7" |
| Converting width max. | 340 mm | 13.4" |

| Printing | | |
|------------------------------------|--------|-----|
| Repeat length max. | 508 mm | 20" |
| Repeat length min. | 254 mm | 10" |
| Number of printing operations max. | 3 | |
| Anilox and plate cylinder | Sleeve | |

| Drying | | |
|----------------|---|--|
| UV | ✓ | |
| Hot-air drying | ✓ | |

| Semi-rotary processing | | |
|--------------------------------------|----------|-----|
| Repeat length max. | 508 mm | 20" |
| Repeat length min. | 254 mm | 10" |
| Number of processing operations max. | 2 | |
| Die cutting cylinder | magnetic | |

| Substrates | | |
|--------------|----------|--|
| PS materials | standard | |

| Remote diagnosis | | |
|------------------|---|--|
| HEIRES access | ✓ | |

All technical data represent approximate values. Gallus reserves the right to make mechanical and design modifications.

Gallus Ferd. Ruesch AG
Harzbüchelstrasse 34
9016 St. Gallen, Switzerland
T +41 71 242 86 86
F +41 71 242 89 89
info@gallus-group.com
www.gallus-group.com

Gallus ECS C

The modular converting system.

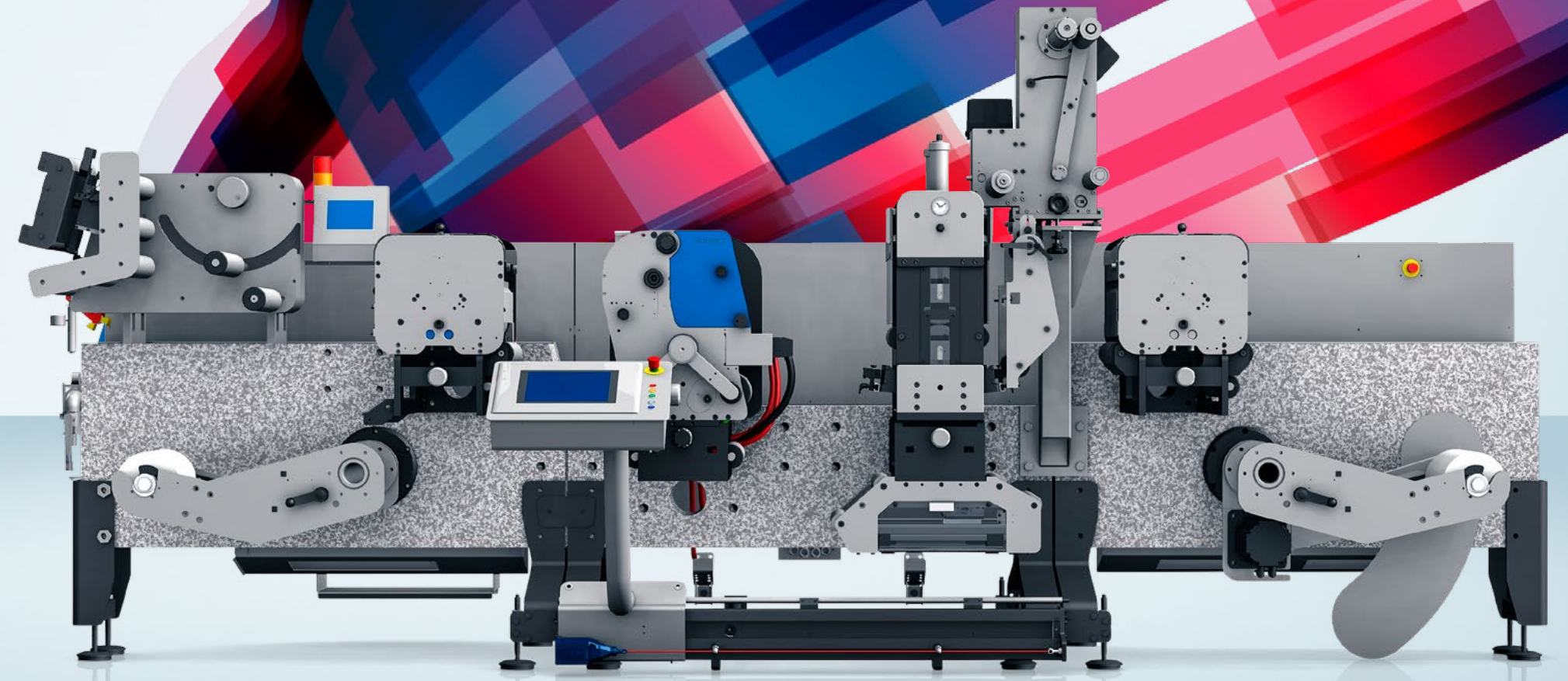

Combining the best benefits into one system.

Under the banner of «high performance digital converting», the Gallus ECS C Digital Converting System combines the best from conventional label printing with the possibilities offered by digital printing.

Solid base

A digital converting solution has been created based on the revolutionary Gallus ECS 340, with the innovative, format-free die cutter at its heart. Minimal changeover times and virtually waste-free job changes are made possible by front loading, a sleeve system, chambered doctor blade, presetting and an extremely short web path. The robust design based on technical granite in conjunction with Gallus register control ensures exceptionally smooth operation and high processing quality even at very high speeds.

High productivity

Developed to handle the output of up to two highly productive digital presses, the Gallus ECS C Digital Converting System can be used whenever there is a need for uncompromising productivity at minimal cost per label.

Modular solution

The modular structure also opens up an unexpectedly wide range of applications. Almost any configuration is possible, from the compact version consisting of a die cutter and flexographic printing unit to a multicolour configuration with surface finishing processes.

Maximum productivity combined with top quality.

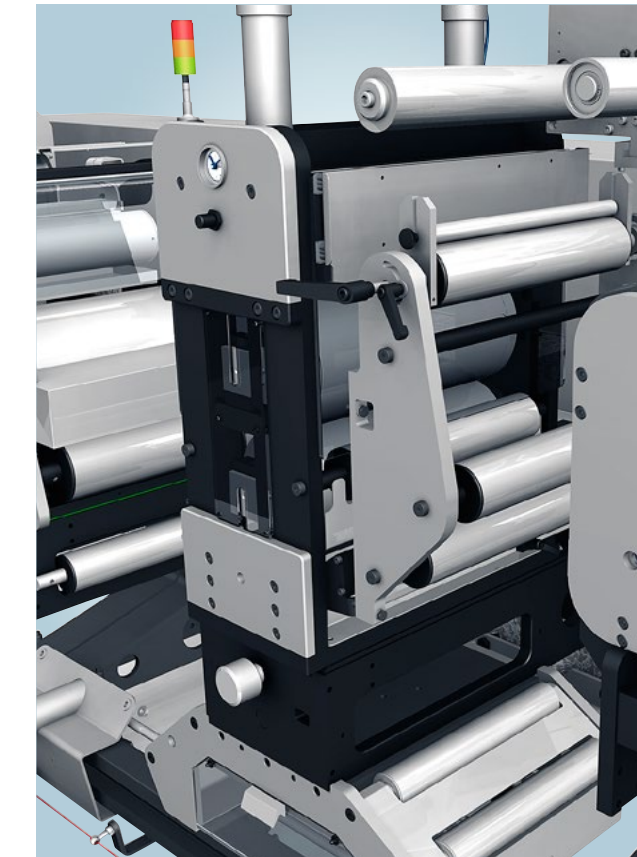

No format-dependent die cutting assemblies thanks to semi-rotary die cutter.

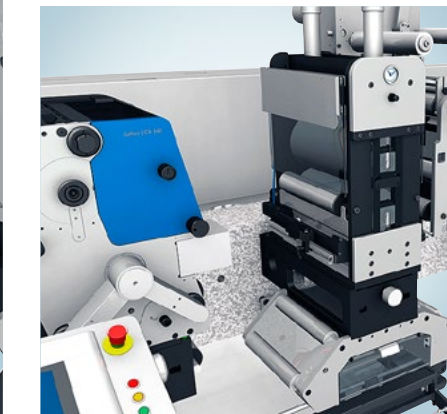

Short web path and print register presetting for minimal paper waste and fast setup.

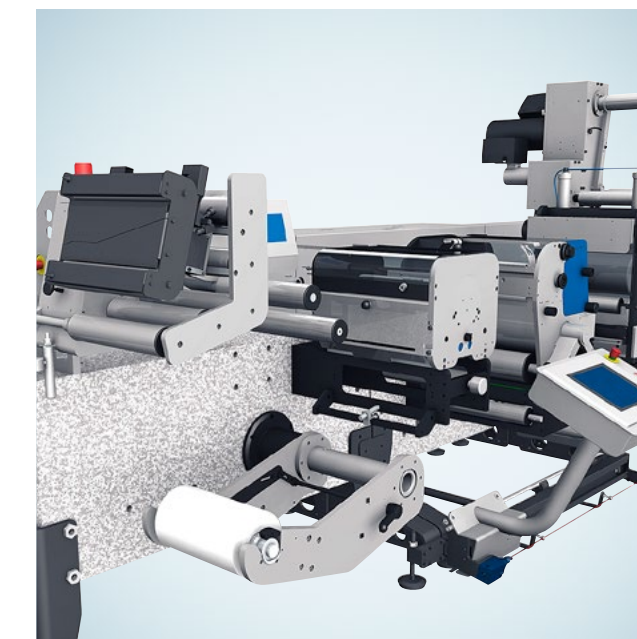

Ergonomic and compact cleaning for straightforward and efficient operation.

